

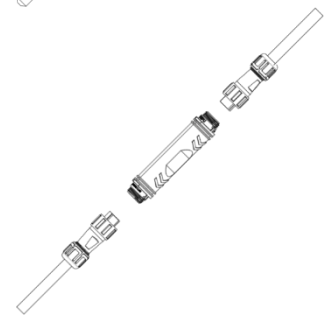

USER GUIDE

Version 2.1

2nd Gen Slim Model

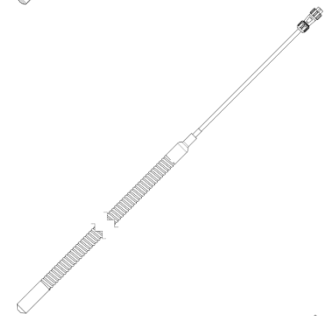
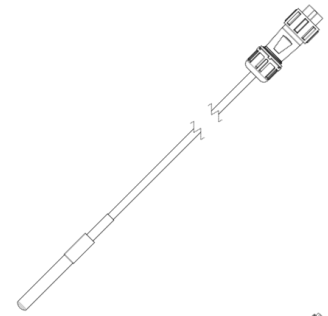
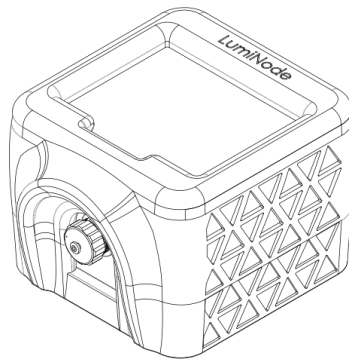
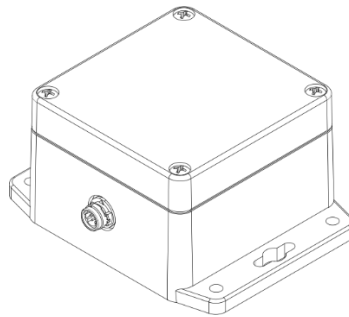
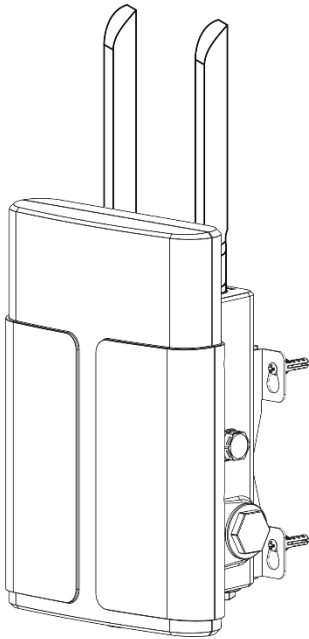

LumiCon User Guide

TABLE OF CONTENTS

1	System Overview and Components	2
1.1	Parts List.....	2
1.2	System Overview & System Components.....	3
2	Set up and Mount LumiHub (2 nd Gen Slim Model).....	4
2.1	Installation Location.....	4
2.2	Antenna Installation & Gateway Preparation.....	5
2.3	Mounting and Power Connection.....	6
2.3.1	Mounting to Pole.....	6
2.3.2	Mounting to Wall.....	7
2.4	Power Supply Setup and Connection.....	8
2.4.1	Power Supply Box Setup.....	8
2.4.2	Power Supply Reel Setup.....	9
2.4.3	Powering on the LumiHub.....	10
3	Set up LumiCon Mobile Application.....	11
4	LumiSense and LumiNode Installation.....	16
5	Job Completion.....	17
5.1	Stop the In-App Job Monitoring.....	17
5.2	Unmount the LumiNode.....	18
6	Charging the LumiNode.....	20
7	Troubleshooting Steps.....	21

1 SYSTEM OVERVIEW AND COMPONENTS



1.1 PARTS LIST

Description	Quantity
LumiHub	1
LumiHub Power Supply	1
LumiNode	As required
LumiSense cables	As required
Zip ties‡	As required

‡ Zip ties: 1 per *LumiNode* (provided) + 1 for every 2 ft of *LumiSense Cable* (not provided)

1.2 SYSTEM OVERVIEW & SYSTEM COMPONENTS

LumiHub

Accessories

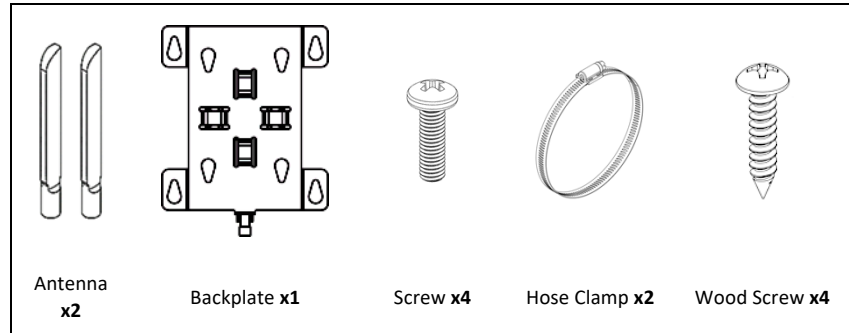
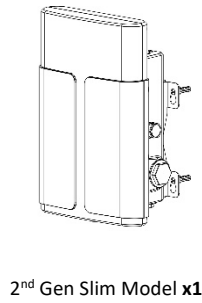

LumiHub Power Supply Options

1x

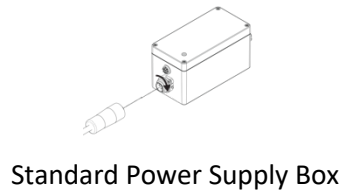

OR

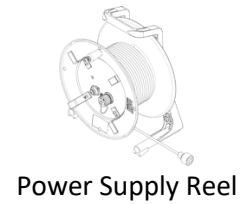

LumiNode

LumiSense

As Required

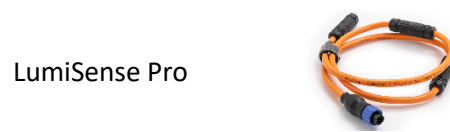
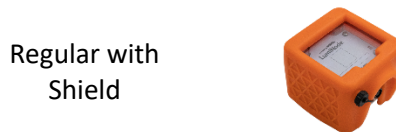

2 SET UP AND MOUNT LUMIHUB (2ND GEN SLIM MODEL)

2.1 INSTALLATION LOCATION

In typical construction sites our LumiHub covers a 500-meter radius. If a line of sight between the LumiHub and a LumiNode can be maintained, up to 2km is possible from our previous site tests. However, environmental factors particular to each job site can significantly reduce the coverage area, such as:

- Job site layout
- Grading
- Equipment in use (Mobile generators and other radio equipment, for example)
- Line-of-sight obstructions by thick concrete slabs or walls
- Large bodies of water on the path between the LumiHub and LumiNode

Our recommendation is to mount the LumiHub on a high location, as exemplified in the pictures below‡.



‡Standard version of LumiHub is shown for illustration purposes only.

2.2 ANTENNA INSTALLATION & GATEWAY PREPARATION

Remove the protector cap of the ANT1 port (and ANT2 if you have 2 antennas). Screw in the antenna(s).

DO NOT USE PLIERS OR WRENCHES. HAND TIGHTEN ONLY.

If your system only uses 1 antenna, ensure to connect it to the ANT1 port.

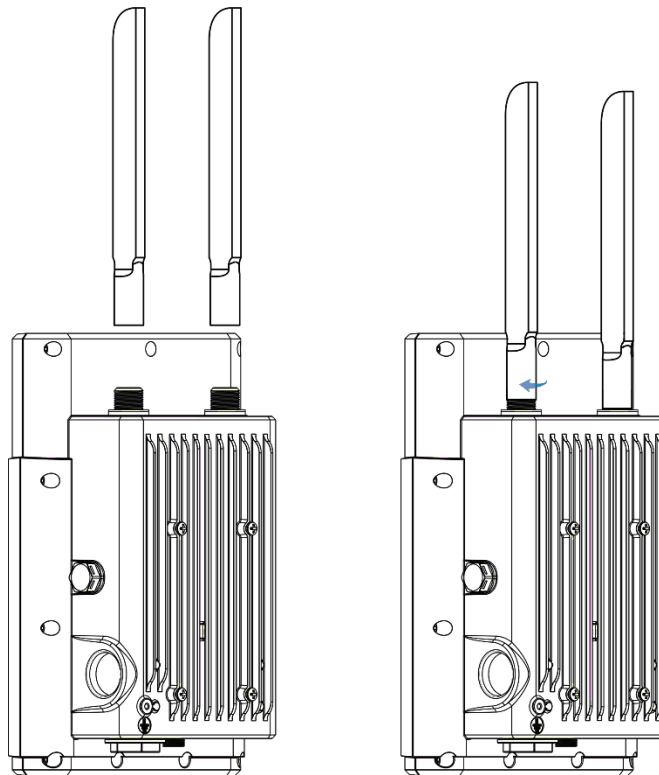

2.3 MOUNTING AND POWER CONNECTION

Pole Mounting instructions (*below*)

Wall Mounting instructions (*next page*)

2.3.1 Mounting to Pole

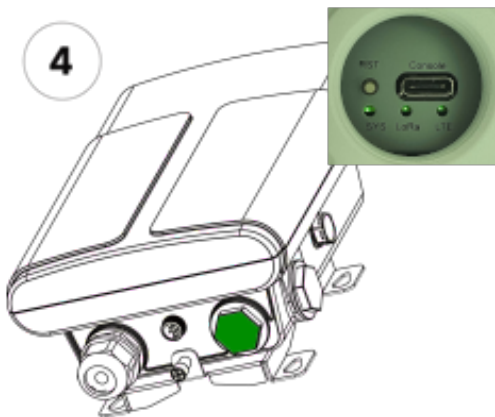
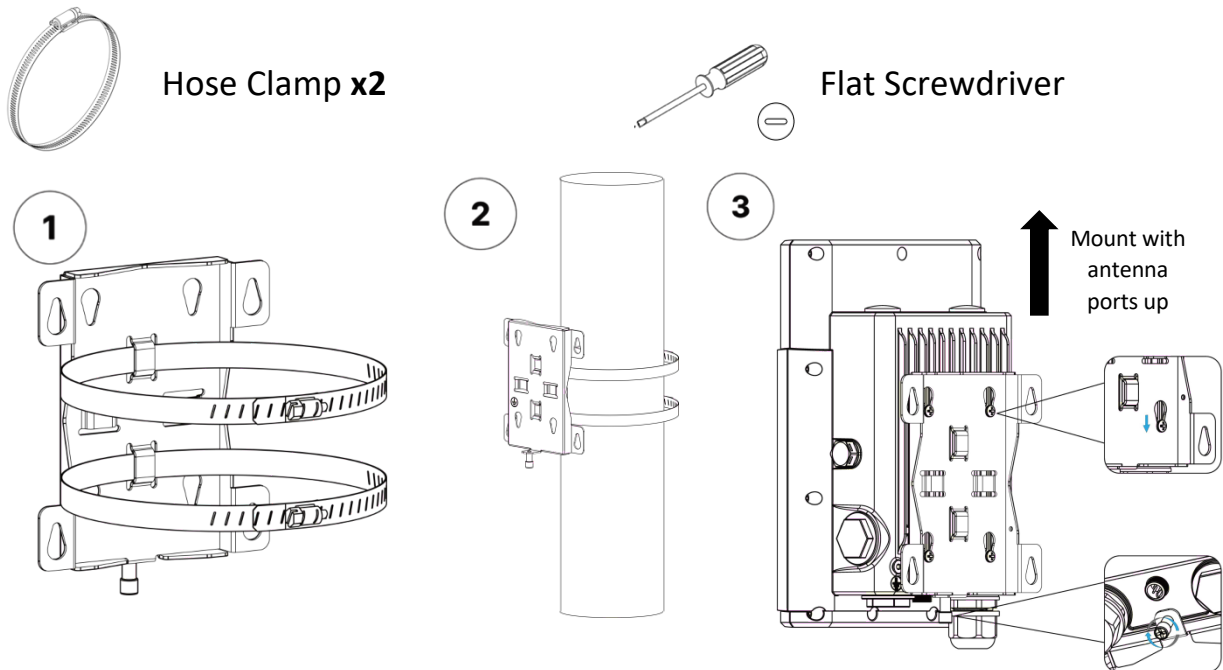

LED	Status	Description
SYS	Green	Gateway operational
	Red	Gateway failure
LoRa	Green	Wireless sensor network operational
	Off	Wireless sensor network not enabled
LTE	Solid Green	LTE connection operational
	Rapid Green	SIM is dialing up
	Slowly Green	SIM is registered
	Off	SIM card not detected or fails to register

Wall Mounting instructions (*below*)

2.3.2 Mounting to Wall



Wood Screw x4

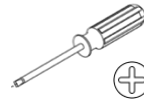

Phillips Screwdriver

1

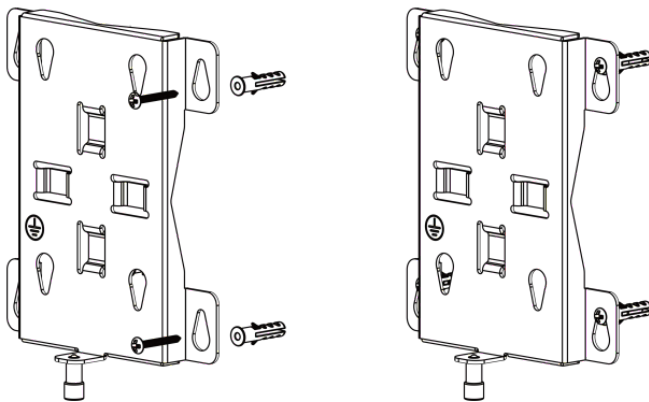

2

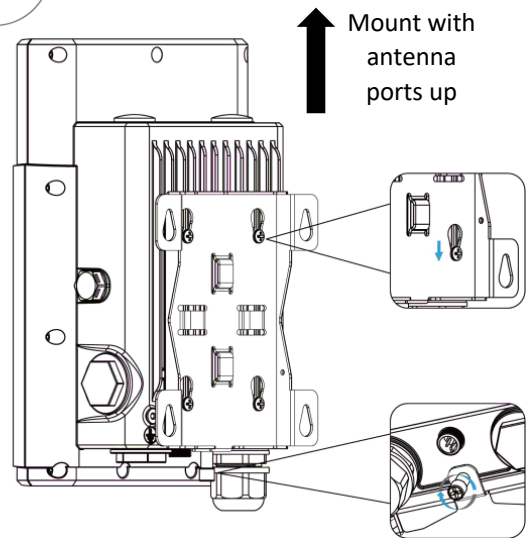

3

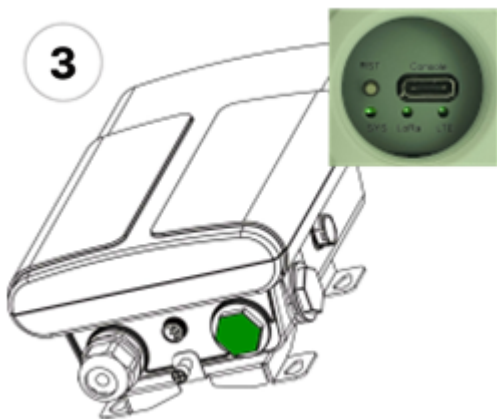

LED	Status	Description
SYS	Green	Gateway operational
	Red	Gateway failure
LoRa	Green	Wireless sensor network operational
	Off	Wireless sensor network not enabled
LTE	Solid Green	LTE connection operational
	Rapid Green	SIM is dialing up
	Slowly Green	SIM is registered
	Off	SIM card not detected or fails to register

2.4 POWER SUPPLY SETUP AND CONNECTION

Power Supply Box instructions (*below*)

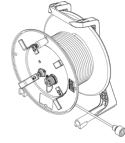

Power Supply Reel instructions
(*next page*)

2.4.1 Power Supply Box Setup

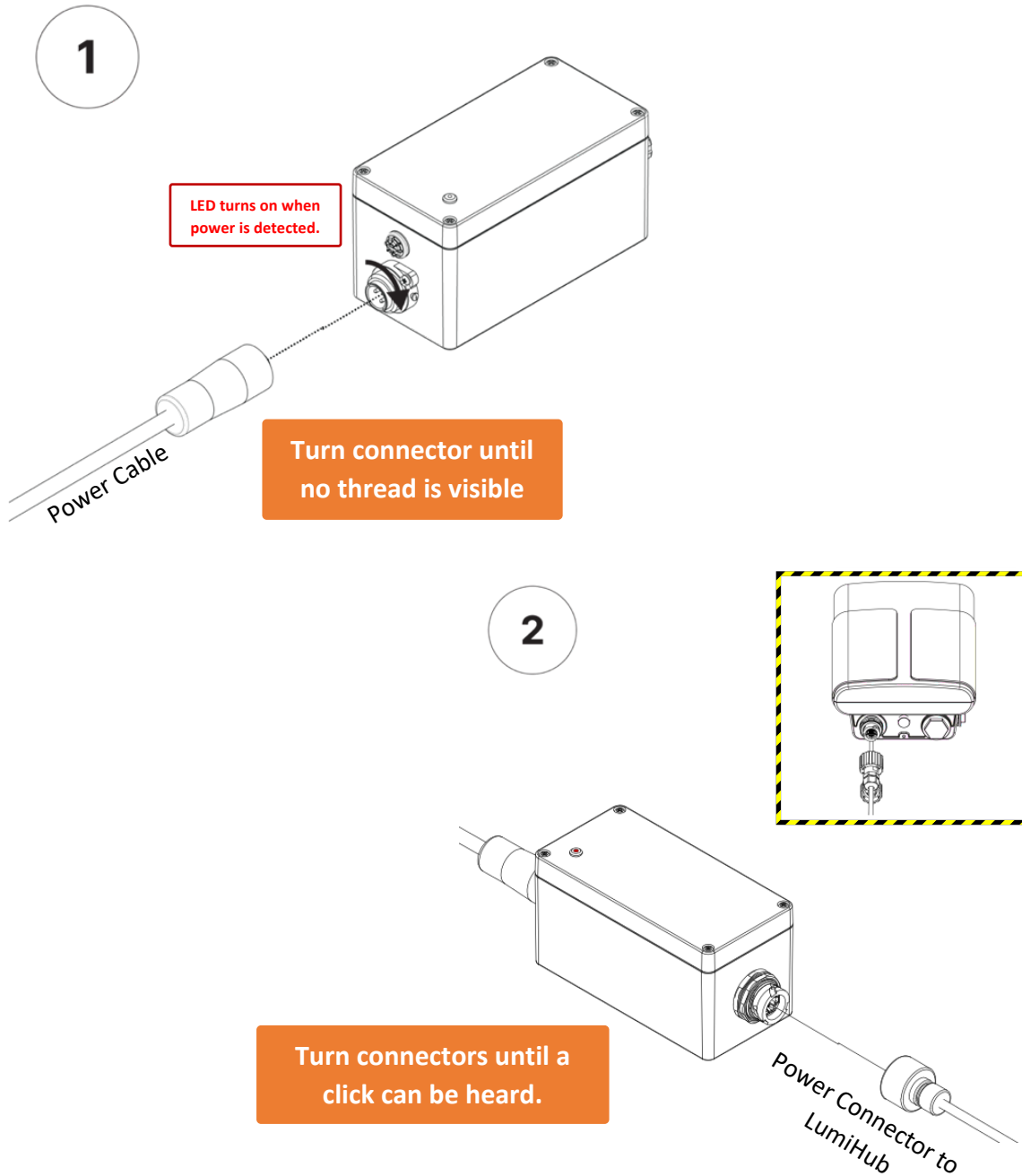

Power Supply Reel instructions (*below*)

2.4.2 Power Supply Reel Setup

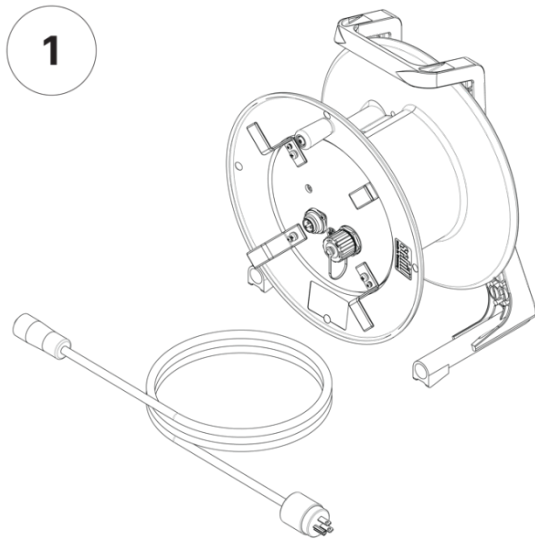

1 Unwind the AC cable from front panel.

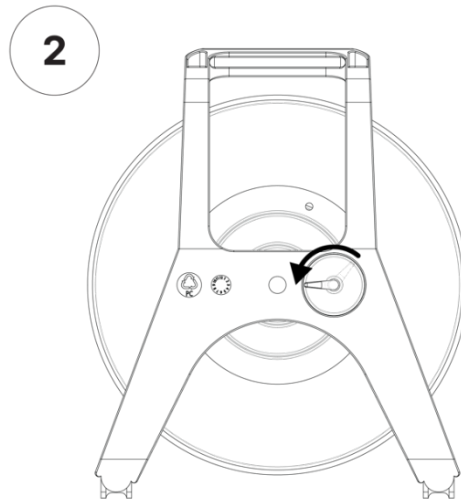

2 Turn dial on the back to lock/unlock reel.

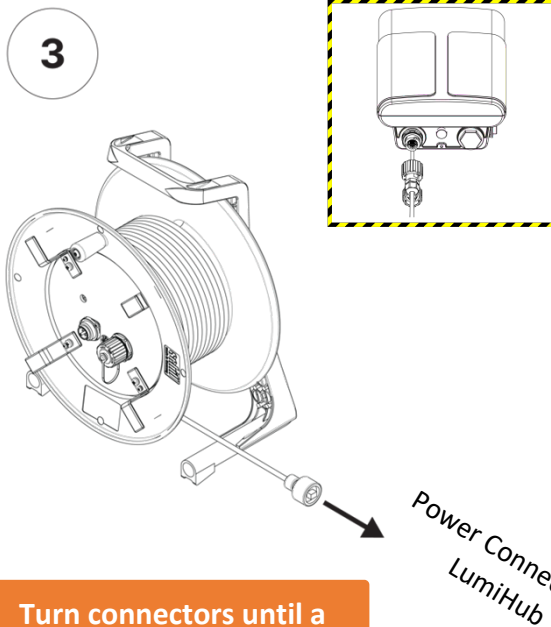

3 Turn connectors until a click can be heard.

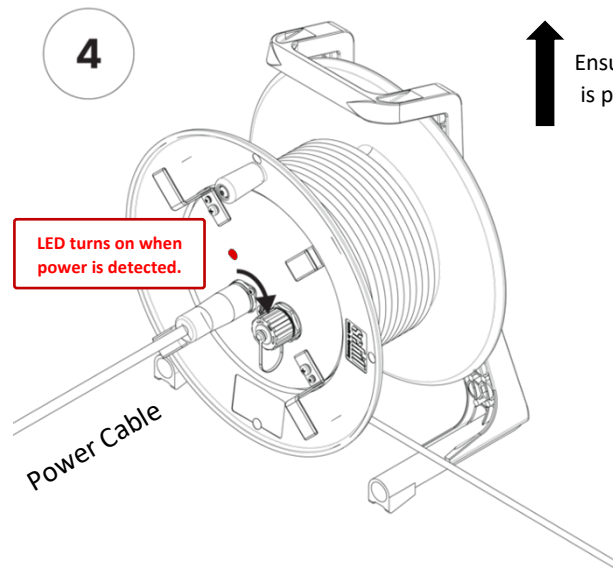

4 Turn connector until no thread is visible.

↑ Ensure handle is pointed up

WARNING! READ BELOW CAREFULLY BEFORE USE
Use the reel in upright position at all times. Do not use the reel in any other orientation.
Ensure all electrical plugs are fully inserted and tightened before powering on the equipment

2.4.3 Powering on the LumiHub

Insert the end of the LumiHub Power Cable into the ethernet jack, indicated below:

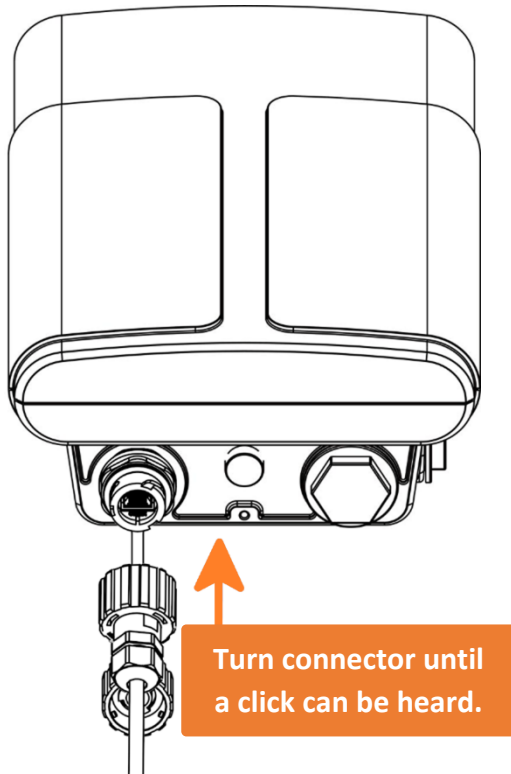

The assembled system should look something like this:

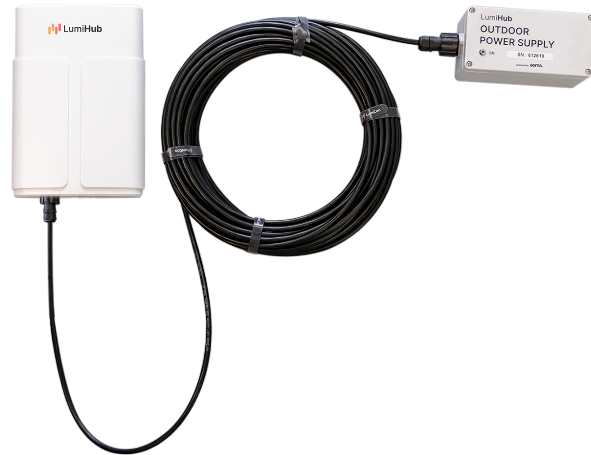

Power Supply Box with no power cord shown



LED	Status	Description
SYS	Green	Gateway operational
	Red	Gateway failure
LoRa	Green	Wireless sensor network operational
	Off	Wireless sensor network not enabled
LTE	Solid Green	LTE connection operational
	Rapid Green	SIM is dialing up
	Slowly Green	SIM is registered
	Off	SIM card not detected or fails to register

3 SET UP LUMICON MOBILE APPLICATION

Download the LumiCon mobile application from either the Google Play Store or the Apple App Store.



STEP 1 Enter the following credentials to access the LumiCon app:

- Authentication Code
- Username
- Password

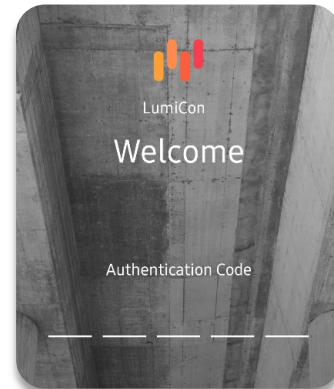

STEP 2 The main dashboard contains all created Job Sites you have access to.
Tap on “New Job Site” to create a new job site.

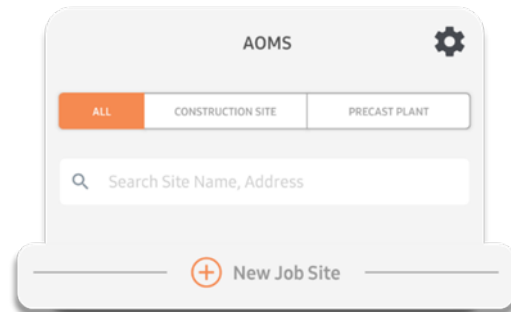

STEP 3 Enter a site name, address, and other details about the Job Site.

Scan the QR code found on the side of the **LumiHub** or manually enter its ID.

Tap “Add”. Then tap on your newly created Job Site on the main dashboard.

The system will ask you if you want to invite other users to have access to your Job Site. Follow the prompts if you would like to do so at this point.

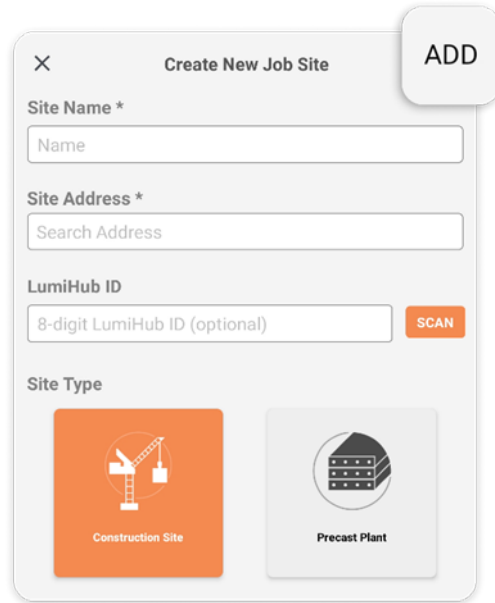

The screenshot shows a mobile app interface for creating a new job site. At the top, there is a close button (X) and the title 'Create New Job Site', with an 'ADD' button in the top right corner. The form contains the following fields: 'Site Name *' with a text input field labeled 'Name'; 'Site Address *' with a text input field labeled 'Search Address'; 'LumiHub ID' with a text input field labeled '8-digit LumiHub ID (optional)' and a 'SCAN' button; and 'Site Type' with two selectable options: 'Construction Site' (represented by an orange icon of a crane) and 'Precast Plant' (represented by a grey icon of a building).

STEP 4 The main dashboard groups projects into “Concrete Sensors”, “Job Site Sensors”, and “Materials Tracking.”

Tap on Concrete Sensors and then tap “New Project” to add a new project.

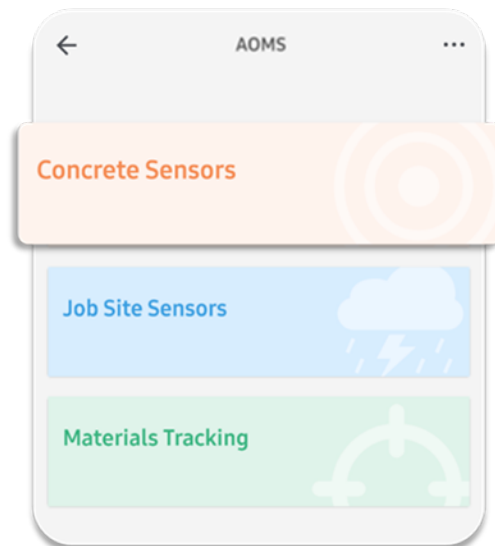

BEST PRACTICES

If you have created a **construction site**, you do **not** have the option to create a Project. Skip to STEP 7.

STEP 5 Enter a Project name.
Tap “Add”.

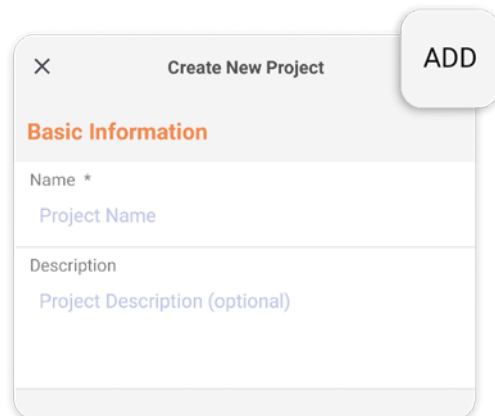

The screenshot shows a mobile app interface for creating a new project. At the top, there is a close button (X) and the title 'Create New Project', with an 'ADD' button in the top right corner. The form is titled 'Basic Information' and contains the following fields: 'Name *' with a text input field labeled 'Project Name'; and 'Description' with a text input field labeled 'Project Description (optional)'. There is a large empty space below the description field.

STEP 6 Once your Project is saved, it is visible on the main page. Tap on the Project that was created to access the Jobs page.

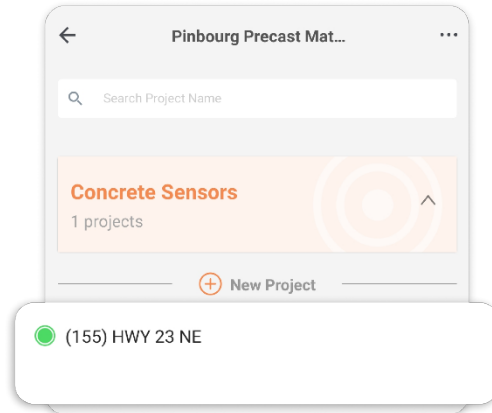

STEP 7 Tap on "New Job" to create a new job.

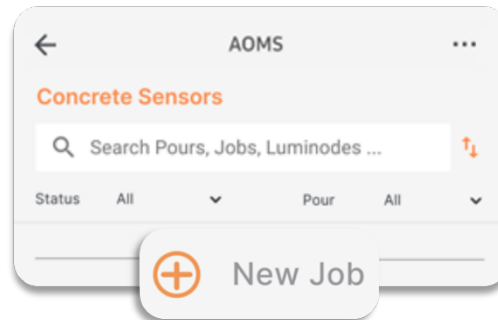

STEP 8 Enter a name for your Pour. It should be an identifier for the concrete element you want to monitor.

Example: Footing 123A

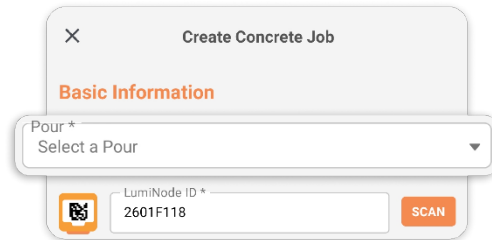

Scan the QR code found on the front face of the **LumiNode** or manually enter its ID.



Scan the QR code found on the **LumiSense** cable tag or manually enter its ID.



STEP 9 Enter a job name and optional description. Usually, the job name is related to the sensor locations inside the object you are monitoring.

Example: Gridline 3 – South Side.

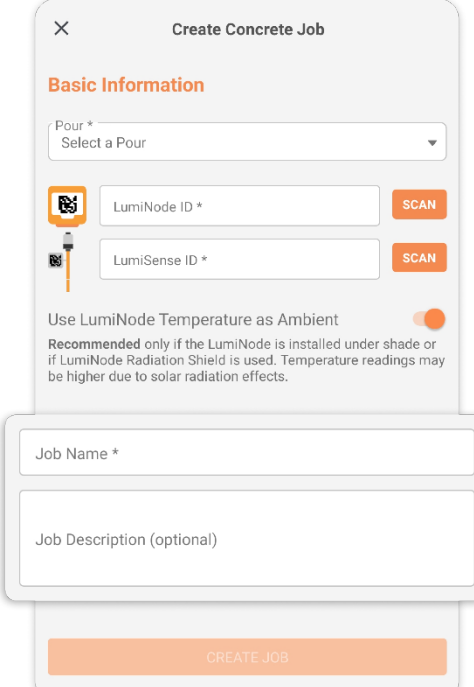

Create Concrete Job

Basic Information

Pour *
Select a Pour

LumiNode ID *

LumiSense ID *

Use LumiNode Temperature as Ambient

Recommended only if the LumiNode is installed under shade or if LumiNode Radiation Shield is used. Temperature readings may be higher due to solar radiation effects.

Job Name *

Job Description (optional)

STEP 10 Scroll down to the bottom and click “Create Job” (you can create temperature differentials and a concrete profile later).

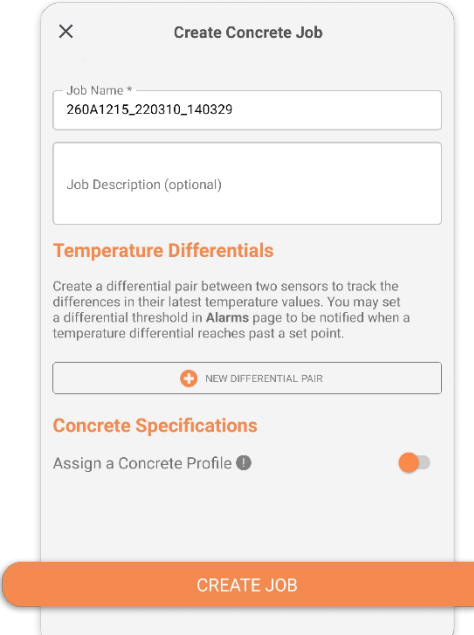

Create Concrete Job

Job Name *
260A1215_220310_140329

Job Description (optional)

Temperature Differentials

Create a differential pair between two sensors to track the differences in their latest temperature values. You may set a differential threshold in **Alarms** page to be notified when a temperature differential reaches past a set point.

Concrete Specifications

Assign a Concrete Profile

STEP 11 When the new job is saved, it will be visible in the jobs view.

Pending Jobs will have a yellow status icon. Although data will still be saved to the job, the application doesn't consider it to be concrete data just yet. Therefore, no calculations are running, and no alarms will be triggered.

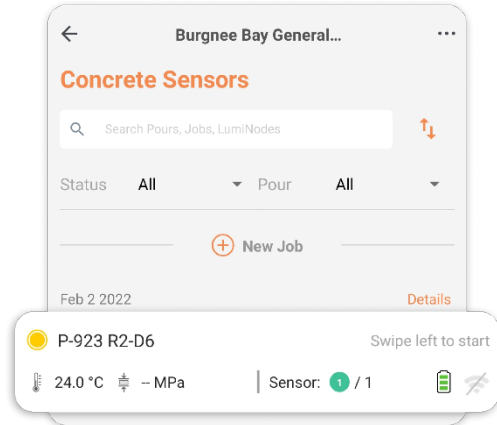

STEP 12 Insert the LumiSense cable into the LumiNode by aligning the white dots located at the connectors. Tighten the nut until no threads are visible ensure a watertight seal. The "Link" LED on the LumiNode will start flashing. The latest data will now update on the LumiCon app.

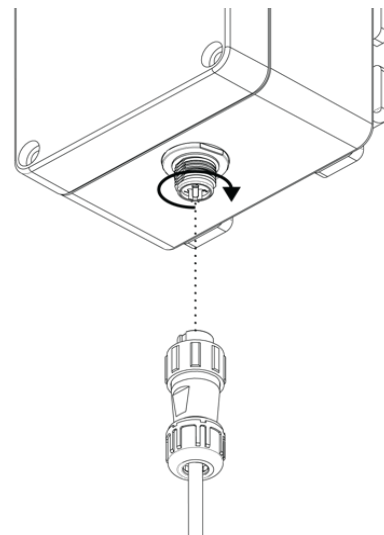

BEST PRACTICES



Only connect the LumiSense cable to the LumiNode **after the job has been successfully created** on the LumiCon app.

STEP 13 Once the pour has occurred and strength calculations are ready to begin, start the job. To start a job, slide the job card to the left and tap on the green power icon.

BEST PRACTICES



Start the job the moment your **last concrete sensor has been encased in concrete**.

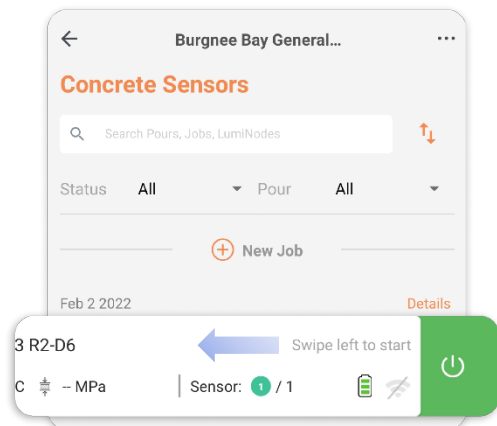

4 LUMISENSE AND LUMINODE INSTALLATION



Zip ties **1 per LumiNode (provided)**
1 for every 2 feet of LumiSense cable (not provided)

1

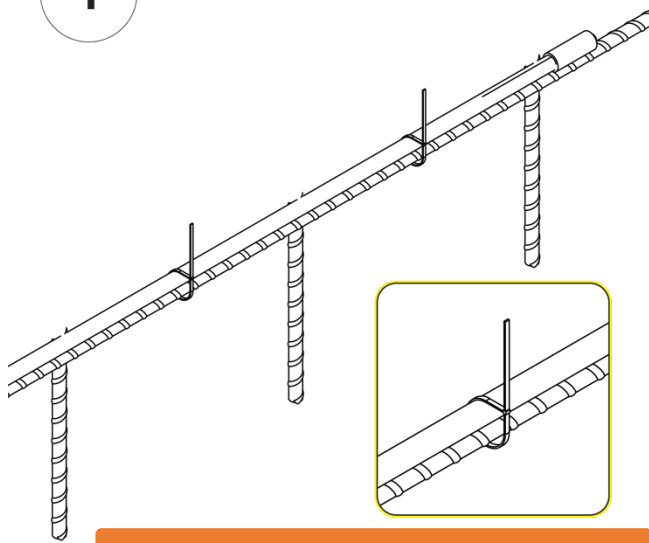

Ensure zip ties are placed and secured at every 2 feet of the rebar.

2

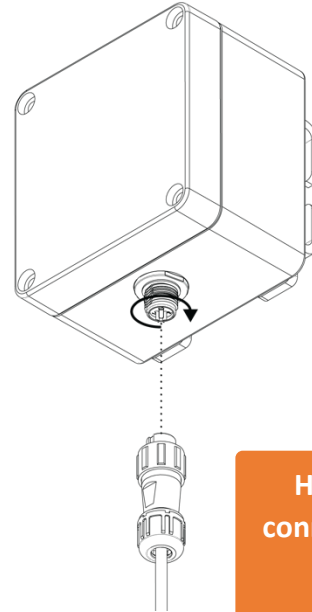

Hand tighten connector, do not use tools.

3

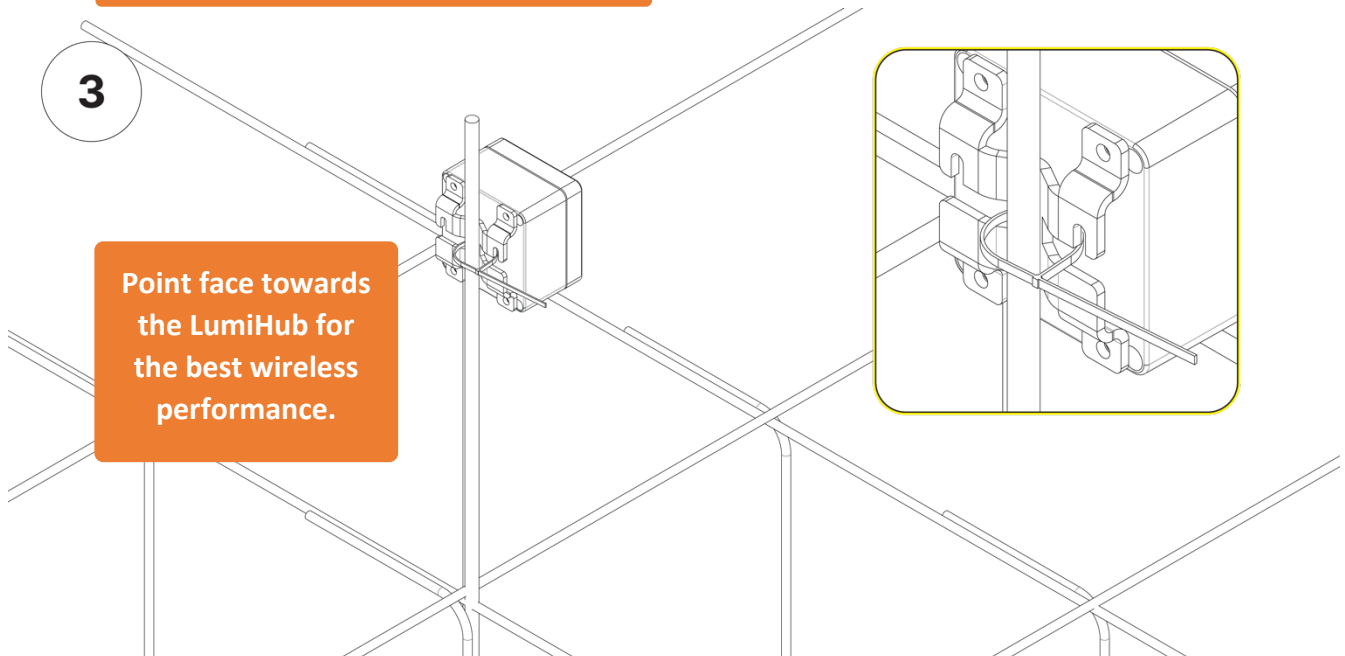

Point face towards the LumiHub for the best wireless performance.

5 JOB COMPLETION

5.1 STOP THE IN-APP JOB MONITORING

When a pour reaches maturity and no longer requires monitoring, you will need to stop the job on the LumiCon app to prevent further alarms from being triggered.

STEP 1 Enter the following credentials to access the LumiCon app:

- Authentication Code
- Username
- Password

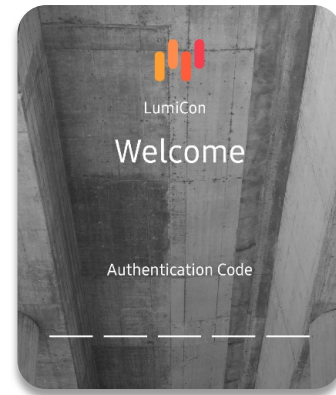

STEP 2 Navigate to the Job Site containing the Job you are trying to stop. You can use the search bar to quickly find it.

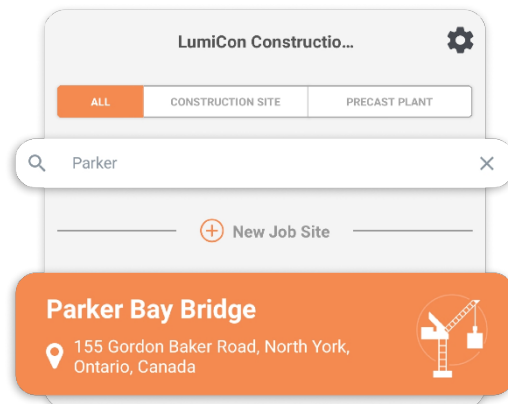

STEP 3 Navigate to the Project. You can also use the search bar to quickly find it.

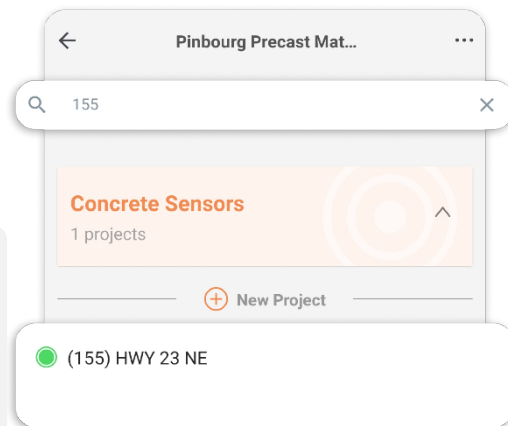

BEST PRACTICES

Projects are only available to Precast Plants. If your Job Site is a construction site, skip to STEP 4.

STEP 4 In the Jobs page, find the Job that has now completed. Swipe to the left to reveal the button to stop the Job.

Please note that this step is not reversible, follow the prompts to complete the process.

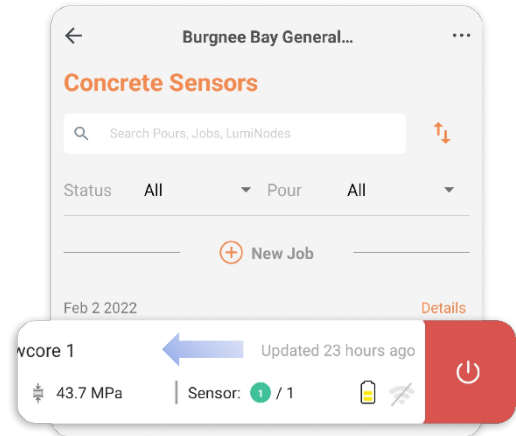

Jobs that have stopped will have a grey status, active jobs will have a green status, and pending jobs will have a yellow status.

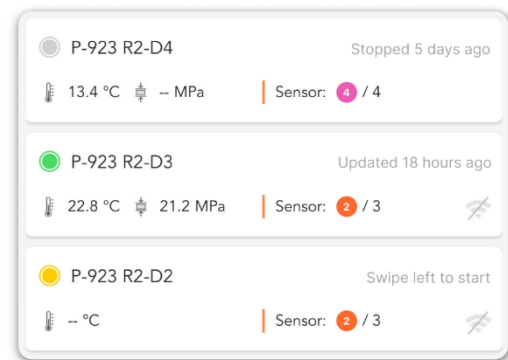

5.2 UNMOUNT THE LUMINODE

After the job is complete, the LumiSense Cable will be consumed if encased in concrete, but the LumiNode can be used again for the next temperature monitoring job.

1. Unplug the LumiSense Cable from the LumiNode, and **immediately twist on the LumiNode cap** to protect the port. LED will stop flashing once unplugged.

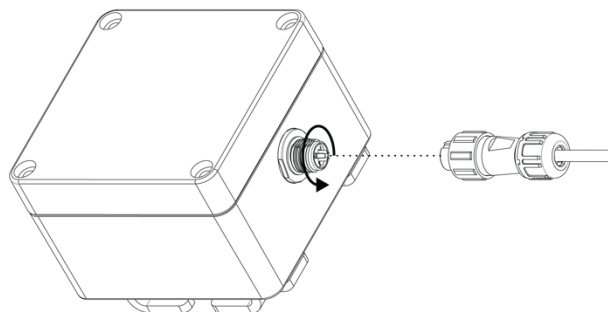

2. Release the LumiNode by cutting or unlocking the zip-tie holding the LumiNode in place.

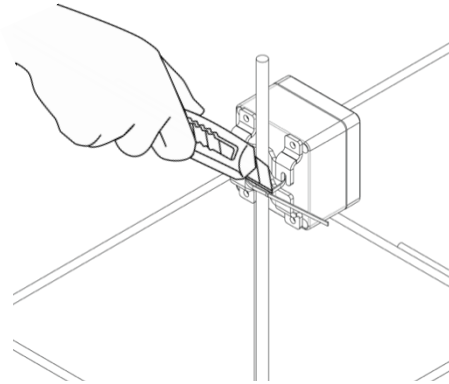

3. You may use this LumiNode immediately for another Job or put it in the original packaging for safe storage.

6 CHARGING THE LUMINODE

You must use the USB charger brick and USB-C cable that came with the LumiNode to charge the LumiNode.

After plugging in the charger, one of the three LEDs in the battery icon will start flashing depending on the current battery level. The LumiNode will typically fully recharge in 8-24 hours, depending on the state of the battery.

The three LEDs will remain solidly lit when the device is fully charged.

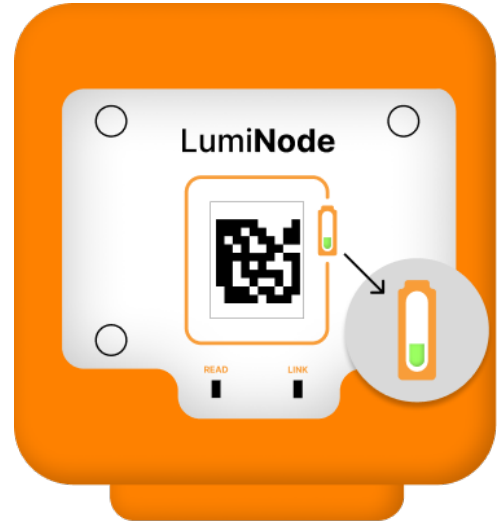

IMPORTANT NOTE



Ensure the rubber insert is re-installed onto the USB-C port after charging. Failure to do so may lead to damage to the charger port due to the accumulation of debris and water inside the port.



7 TROUBLESHOOTING STEPS

